

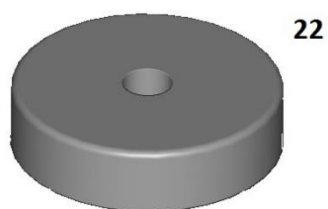

INSTRUCTIONS FOR USE
Debut PRO S

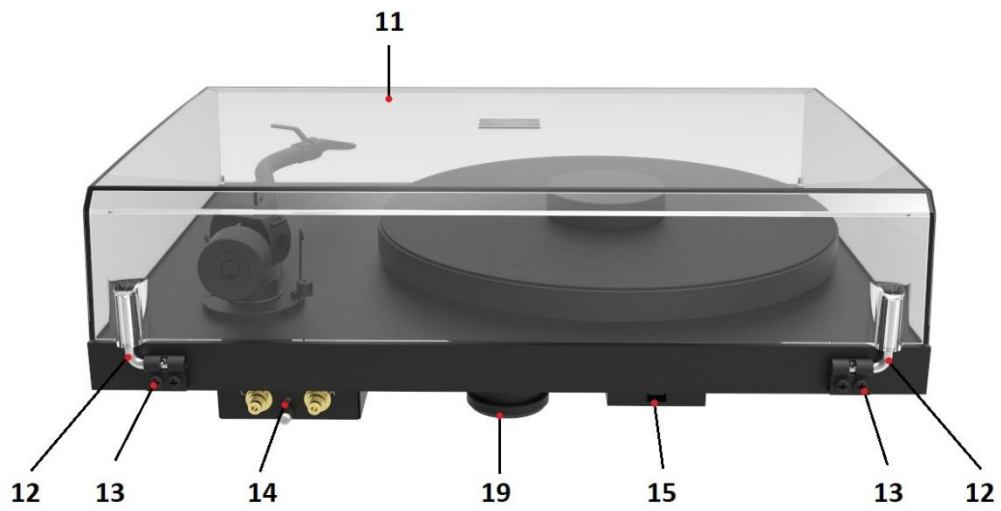
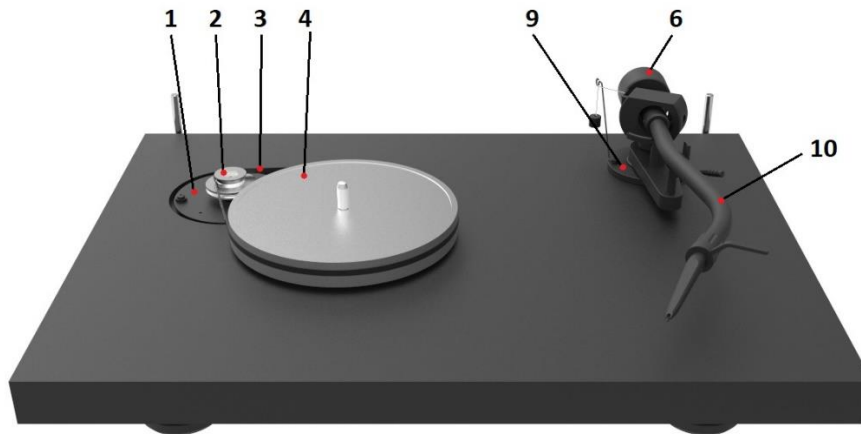
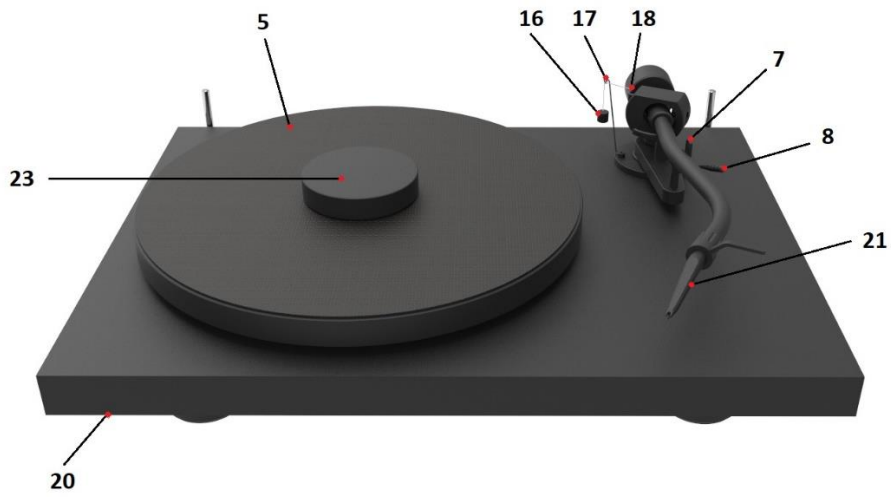

Pro-Ject Debut PRO S

Controls, features and connections

- 1 Motor with TPE damped flange
 - 2 Stepped drive pulley
 - 3 Drive belt
 - 4 Aluminium sub-platter
 - 5 Platter with TPE damping and felt mat
 - 6 Tonearm counterweight
 - 7 Tonearm rest and removable transport lock
 - 8 Tonearm lift lever
 - 9 Tonearm base with VTA adjustment
 - 10 Tonearm tube
 - 11 Lid
 - 12 Lid hinges
 - 13 Hinge fasteners
 - 14 Phono output sockets and earth connection
 - 15 Power supply socket
 - 16 Anti-skating weight
 - 17 Anti-skating weight support hoop
 - 18 Anti-skating weight adjustment scale
 - 19 Height adjustable feet with TPE damping
 - 20 Speed selector
 - 21 Pro-Ject Pick it S2 C cartridge
 - 22 Single adapter
 - 23 Record Puck E
- Phono cable Connect it E (not shown)
Stylus pressure gauge (not shown)
Two-point cartridge alignment protractor (not shown)
Round drive belt (78 RPM)
Flat drive belt (33, 45 RPM)
Allen key 1.5mm, 2mm



During assembly and adjustment of the deck small parts could be lost if not carefully placed in a suitable receptacle. Before starting to assemble, get familiar with the parts listed above and correspondingly numbered in the technical drawings above.

Dear music lover,

Thank you for purchasing your Debut PRO S.

Since 1991 we have been offering high-quality hi-fi products at a reasonable price for discerning music lovers. We started with turntables because they are the first choice for the most natural and affordable music reproduction. Our main focus is always on the materials and technology used. The shape and design of our turntables are always dictated by the functionality.

To this day, our designs have always been kept functional and clean, so the first Pro-Ject product was very simple but made from the highest quality materials: MDF, steel, aluminium, glass, and carbon. Plastic was not used for reasons of sound, durability, and the love of the environment.

The result was a high-quality but simple-looking product with great sound at a low price.

Our turntables demand conscious music listening. The Debut PRO S takes this philosophy to the extreme. We finished all parts except for the polished spindle in matte black. The manual controls invite the listener to interact with the turntable: turn it on, place the record on the platter, move and lower the tonearm. The musical reward follows the tactile experience. No unnecessary switches, LEDs, or labeling distract from what is essential.

In order to achieve maximum performance and reliability with new Debut PRO S please read this guide carefully!



Warning of a hazard for the user, the unit or possible misuse.



Important notice.

Safety instructions

The power supply is used to connect and disconnect the unit from the mains. Make sure that the plug is easily accessible at all times. Hold the plug when unplugging the power cord. Never handle the power cord while your hands are wet or damp.



Avoid letting liquids enter the device. Never place any item containing liquid, like a flower vase, on or near the device. Never spill any liquid on the device. Never place any naked flame sources, like lighted candles, on or near the device. The product shall not be used in damp or wet locations, next to a bathtub, sink, swimming pool or any other similar conditions.

Keep plastic bags away from children to prevent any risk of suffocation.

First Set-up – Making your Debut PRO S ready for playback

The deck is supplied partially disassembled and carefully packaged for safe transport. The Setup Guide, included in the packaging with your Debut PRO S, explains the setup process step by step with pictures, so be sure to follow it first and then refer to this guide should you want more detailed explanations. Here, some of the more technical set-up steps are covered in detail and you will gain a lot of important background information which will make you more comfortable with everything your new Debut PRO S has to offer.



PRO Info provides additional background information and insights into your Debut PRO S and can be skipped for the first setup. Read them later on if you want to know everything about your Debut PRO S.

1. Positioning and levelling your turntable

Make sure the surface you wish to use the turntable on is level (use a spirit level) before placing the turntable on it. The height adjustable aluminium feet (19) on the Debut PRO S will also allow you to level the turntable itself, in case you cannot get the surface it is placed on to be level. Great surfaces to put your record player on are typically massive, heavy, stable and also as far as possible away from your speakers. This will avoid the sound of footsteps and other low frequency rumble noises to be transmitted via your floor and furniture/surface and picked up by your turntable. If your record player is super close to your speakers and/or placed on the same surface as your speakers are, then the sound from your speakers will be picked up by your turntable over the sound pressure waves in the air and vibrations from speakers to the surface. It will be a great idea to decouple the speakers from the surface (for example with our Damp it) and/or get a really heavy, massive and decoupled surface for your turntable (for example our Ground it range of accessories). Different locations/rooms/set-up places have different requirements and if you think you might be running into troubles with your set-up, definitely do check these upgrades out, so your Debut PRO S can unfold all of its performance.



2. Cartridge tracking force adjustment (VTF = vertical tracking force)

The counterweight (6) supplied is suitable for our Pick it S2 C cartridge (**Pro-Ject Pick it S2 C** - weight no. **59**). Counterweight for SPU cartridges available as a spare part (**Ortofon SPU** - weight no. **57**). When using different cartridges than the ones supplied with the Debut PRO S, confirm the exact weight of your cartridge before you set the VTF.



Pushing carefully, move the counterweight (6) onto the rear end of the counterweight support rod as shown in the picture below. Place the stylus pressure gauge onto the platter. To set the required VTF, lower the tonearm lift lever as indicated in the illustration and place the tip of the stylus exactly in the point marked 23mN (23mN = 2,3g). If the stylus gauge becomes level, then the correct pressure has been

achieved. However, if there is insufficient or excessive pressure the gauge will either not move or tilt down.

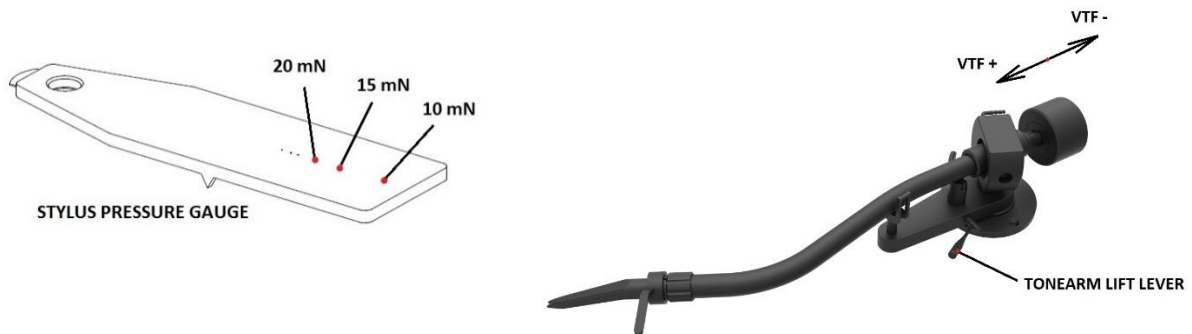

To adjust the amount of pressure, carefully move the counterweight (6) along the support rod, until the stylus pressure is sufficient to raise the pressure gauge to the level position. Moving the counterweight (6) away from the cartridge will reduce pressure and towards will increase pressure.



Please note: Adjust the tracking force prior to installing the anti-skating weight.

The recommended tracking force for the Pro-Ject Pick IT S2 C cartridge is **23 mN = 2.3g**.

Use electronic tracking force scales (like Measure it E) for more accurate results.

PRO Info: Tracking Force

Cartridges usually have a tracking force range as stated by the manufacturer (for example 1.8 – 2.2 grams). The recommended tracking force is a result of the individual cartridge placed on the individual tonearm, the record you play and the wear and age of your stylus. Just to name a few of the most important ones. You are actually free to move within the range and divert from the recommendations. If your stylus is new you want to ideally stay pretty much at the recommendation as a starting point. As it gets older (we are talking many, many thousands of hours playtime) you can apply a little more tracking force. Other reasons why you want more or less tracking force are old/dirty or badly worn records. Experimenting with a little more force might enable you to extract more information out of a worn record groove (don't worry about adding extra wear to the record groove; the groove will wear if you are at 5g not if you are at 2.5g in our example here). If there are scratches in the record or your record tends to skip, changing the tracking force a little higher or lower might also enable you to play these records without skipping.

In general, it is true that if you move beyond the limits of the range as stated by the manufacturer you will negatively affect the longevity of your stylus/cartridge and records. If you really know what you are doing it is however possible to also use a little more tracking force beyond the range to get more tracking ability out of your cartridge. Keep in mind as the tracking force gets higher and higher this will also affect the angle with which the stylus lies in the record groove. Taking the tracking force to 2.4 grams, if the upper limit is 2.2 grams, you will also need to raise the height of the tonearm (also called the VTA – vertical tracking angle). Obviously, we would only recommend this to experienced vinyl enthusiasts as correctly figuring out the VTA setting requires a lot of experience in this case.

3. Anti-skating force adjustment

The anti-skating force must be adjusted corresponding to the downforce as follows:

<u>Downforce</u>	<u>Groove in the stub (18)</u>
10 - 14mN	1 st from bearing rings
15 - 19mN	2 nd " " "
20mN and bigger	3 rd " " "

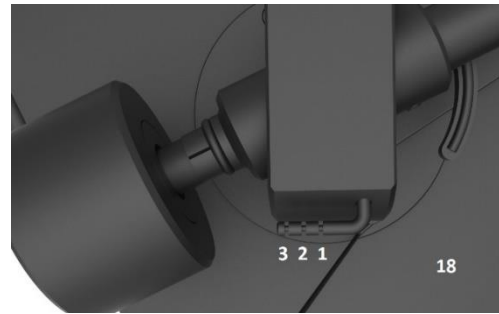

Slip the loop of the anti-skating weight's thread over the third groove of the stub to set the correct anti-skating force for the factory-fitted cartridge. Feed the thread through the loop of the wire support (17).



The Pick it S2 C cartridge on your new Debut PRO S has a recommended tracking force of 23mN (2,3 grams) so the correct groove for the anti-skating is the 3rd groove.

PRO Info: Anti-skating

The anti-skating force counteracts the natural skating of your tonearm and cartridge towards the center of your record. How strong this naturally occurring skating is, depends on a few factors such as the actual physical properties of the record groove, where on the record your tonearm is currently sitting and playing (the skating on the beginning/outside of the record is different than towards the end/inside of your record) and the applied tracking force to name a few of the more important factors. The anti-skating mechanism on your Debut PRO S (and other Pro-Ject Audio Systems turntables) is able to vary the applied anti-skating force, depending on whether the tonearm is on the outside or inside of your record. A lot of other common implementations, like spring or magnet-based anti-skating mechanisms, are not able to vary the applied force based on arm position.

There are a few popular ways to measure the anti-skating force and a few totally wrong ones. Totally wrong would be to use a CD, turn the turntable on and think that anti-skating is set correctly when the tonearm will stay in its place and not move at all. The groove of a vinyl record will generate different levels of friction for the tonearm and is not comparable to a CD at all. Please don't measure the anti-skating force with a CD. The next better option is to use a test record that is made of actual vinyl. The result of the test record can vary, so please be sure you know exactly what your test record is doing and interpret the results correctly. The best way to measure anti-skating is a test record with actual music and test tones and dedicated professional audio and test equipment to measure the actual channel balance and a whole range of other attributes. The anti-skating mechanism of your Debut PRO turntable has been designed with this process. If you are interested in checking anti-skating for yourself, please feel free to buy test records or even use a CD just for the fun of it, but please also keep in mind that you will not achieve the best and accurate results like this, so please treat them with a grain of salt.

Correctly set anti-skating will positively affect the left/right balance, the tracking of the record groove (distortion, frequency response, dynamics) and minimize the wear of record and stylus.

4. Connection to an amplifier (integrated amplifier or phono preamplifier)

The record player has gold plated female RCA Phono sockets (14) on the back. Use the included Connect it E phono RCA cable to connect your Debut PRO S to your amplifier. The cable ends with the yellow markings are plugged into the phono inputs (sometimes also labelled gram, disc or RIAA) on your amplifier. Make sure that the phono input offers correct matching and amplification for the type of cartridge used. Line inputs (such as CD, Tuner, Tape or Video) are not suitable.



The recommended load impedance for the Pick it S2 C is: **47 kohms**

The recommended load capacitance for the Pick it S2 C is: **200 – 600 pF**

Check your amplifier documentation!

Take care to connect the left and right channels correctly. The right channel is usually marked red, the left channel black or white. Check the manual supplied with your amplifier for relevant information. The earthing wire of the tonearm lead should be connected to the earth terminal on your amplifier.

If your amplifier does not have an input suitable for phono cartridges you will require a separate phono amplifier stage for MM cartridges which is then connected between the record player and a free line level input of the amplifier. A separate phono preamplifier can also be helpful if you want to upgrade your sound experience, as external phono preamps are 100% dedicated to making your turntable sound as good as it can possibly be. They are not limited by other restrictions typically found in integrated amplifiers, which are almost always compromising sound quality a bit.

PRO Info: Phono Cable

The included Connect it E phono cable is a semi-balanced phono interconnect cable purpose-engineered for best-in-class turntable performance. It is terminated with high-conductivity RCA connectors for a tight fit that won't come loose when you move your equipment. They're 24k gold plated for optimum signal transfer and corrosion resistance. The Connect it E cable is a parallel symmetrical cable where the shield is only connected on one end. The yellow mark indicates this side. The marked side should always be connected to the receiving end (i.e. phono stage or amplifier). It is pretty rare to find a cable of these high specifications included with turntables, but they are absolutely necessary and so critical for phono performance, which is why Pro-Ject Audio Systems is including them by default. There is no way you can do it without specialised cables like that. If you wish, you can further substitute the supplied Connect it E with even higher quality cables such as the separately available **Pro-Ject Connect IT Phono S, DS or RS**.

For detailed product information regarding Pro-Ject Audio interconnect cables and phono amplifiers please refer to the Pro-Ject web site www.project-audio.com.

5. Mains power connection

The turntable is supplied with the universal power supply with 3 exchangeable sockets adapters suitable for all countries. Select the correct adapter for your country and insert the adapter to the exchangeable part of the power supply.

Connect the low voltage plug from the power supply to the socket (15) on the rear of the record player before connecting the power supply to the mains.

PRO Info: Power Supply Upgrade

Your Debut PRO S already has a speed control unit built in which at the same time already acts as a clean power supply. The exact voltage and frequency for the motor are generated by this speed control unit, resulting in the most accurate playback speeds. Upgrade power supplies (like the High Power it, Power Box DS3 Sources or Power Box RS2 Phono) provide proper grounding and dramatically reduce ground hum of „floating mass“ systems/amplifiers.

Every turntable needs proper grounding, otherwise electrical hum may be induced. If a turntable is not properly grounded, it may have a different reference potential than the connected amplifier. Consequently, these potential differences induce a compensating current which can be heard as hum. Therefore, all good turntables have a separate ground cable which can be connected to standard amplifiers or phono stages, which usually have a ground terminal. This way different potentials are equalized and hum is no longer audible. However, many modern amps, especially most amps of soundbars or streaming speakers have no ground connection. These systems are referenced as “floating mass systems“. If a standard turntable is connected to such a „floating mass“ amplifier, audible hum will be the result.

The Power Box DS3 Sources and Power Box RS2 Phono are also true linear power supplies with a big toroidal transformer and will power other Pro-Ject Audio Systems Box Design HiFi electronics as well.

6. Fitting the lid

Fit the lid (dust cover 11) carefully over the hinge prongs and adjust the screws (13) until the lid stays open where you want it to without being too stiff to open or close.



The lid is not only a dust cover but also a resonant structure likely to be excited by and to pass into the plinth the acoustic energy emanating from your loudspeakers during replay. Therefore, it is recommended to remove the lid completely during vinyl playback for achieving a better sound quality.

7. Switching on and off, changing replay speed

The turntable is equipped with a 3 position switch for electronic speed change. To play records at 33 rpm, move the rocker switch to the left side. To play records at 45 rpm, move the rocker switch to the right side. To be able to play 78 rpm the flat drive belt has to be removed and the round drive belt has to be fitted around the sub-platter (4) and the larger diameter part of the motor pulley (2). To do so, the platter (5) has to be removed.

After the round drive belt has been fitted, moving the rocker switch to the right selects 78 rpm.



PRO Info: Electronic Speed Control

The speed is electronically controlled with precision motor control unit which guarantees the most accurate and stable speeds. Each motor runs at a certain voltage and frequency. The frequency (50Hz) is not taken straight from of your wall power, but cleanly generated by the motor control unit. You will not have any fluctuations in speed caused by slight variances in the frequency from your mains power. The voltage describes how silent your motor will run. Too much or too little voltage or fluctuations in voltage will cause the motor to vibrate, which means that, basically, you are generating noise.

So that no motor vibrations reach the pickup, the Debut PRO S has the new, proven motor suspension first seen in our Debut Carbon EVO, which is responsible for the perfect decoupling of the motor.

Advanced Debut PRO S adjustment options



The following adjustments are NOT necessary for first time set-up but important later on when changing or upgrading the cartridge! For the included cartridge these settings are factory set correctly.

1. Adjusting the azimuth

The cartridge needle must be vertical in the record groove in order to trace the groove wall modulations correctly.



The cartridge on your Debut PRO S that comes pre-adjusted by the factory, is already correctly set up and you do not need to adjust the azimuth anymore! You should check and/or re-adjust the azimuth if you change or upgrade your cartridge.

A small screw at the bearing end of the arm allows incorrect azimuth to be corrected if your needle is not mounted exactly perpendicular to the cartridge body (which is often the case).

Slacken off the screw just enough to be able to revolve the arm tube without applying force. Please note: do not remove the screw completely!

With the aid of a good magnifying glass adjust the needle until it is vertical in the groove (i.e. perpendicular to the record's surface). Ideally this should correspond to the top surface of the cartridge body being parallel to the record surface.

When you are satisfied that the needle is vertical retighten the screw carefully.

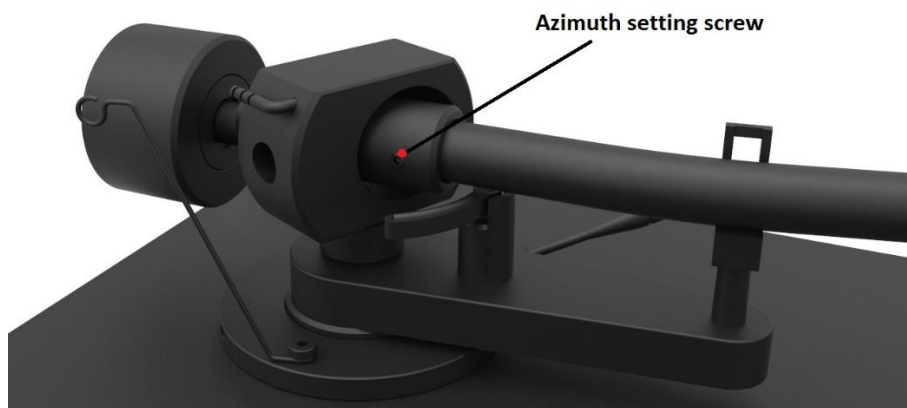

Please note: Under no circumstances should the arm tube be adjusted with the needle still in the record groove! Irreparable damage may be caused to the cantilever suspension! The arm must be lifted to make each adjustment and lowered afterwards to check it.

2. Adjusting the vertical tracking angle (VTA)

Put a record on the platter. When the needle is lowered into the record groove and the tonearm is not resting on the lift arm, the tube of the tonearm should be parallel to the surface of the record.

If it is not, loosen both hexagon screws in the tonearm base just enough to allow vertical movement of the arm pillar without force and slide the arm up or down until it is parallel.



Retighten the hexagon screws without applying excessive force (which would deform the arm pillar) – finger tight is quite sufficient.

3. Tonearm adjustment for Ortofon SPU cartridges

The tonearm needs to be set in new position to be able to use Ortofon SPU cartridges. Please print out the template from page 17.

Place the template on the turntable with its right side flush with the turntable edge and its top side touching the flange, as shown in the illustration below.

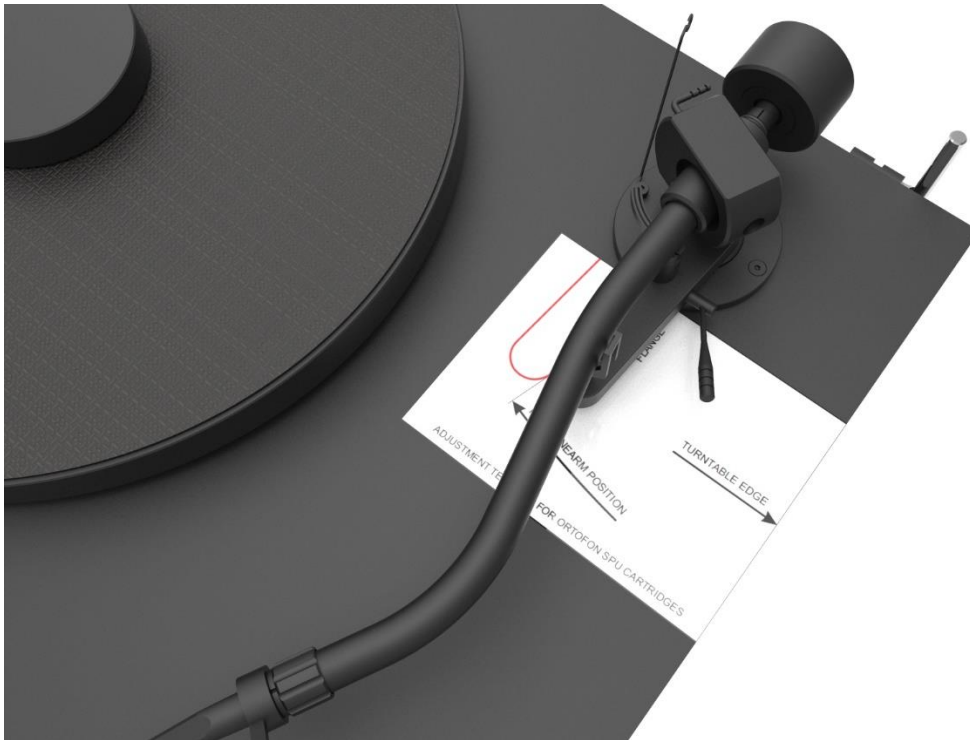

Loosen both VTA setting screws and carefully slide the arm toward the platter so that the tonearm support follows the new position shown on the template.



When the tonearm is in the correct position, retighten both VTA setting screws. Now the tonearm is ready to use Ortofon SPU cartridges.

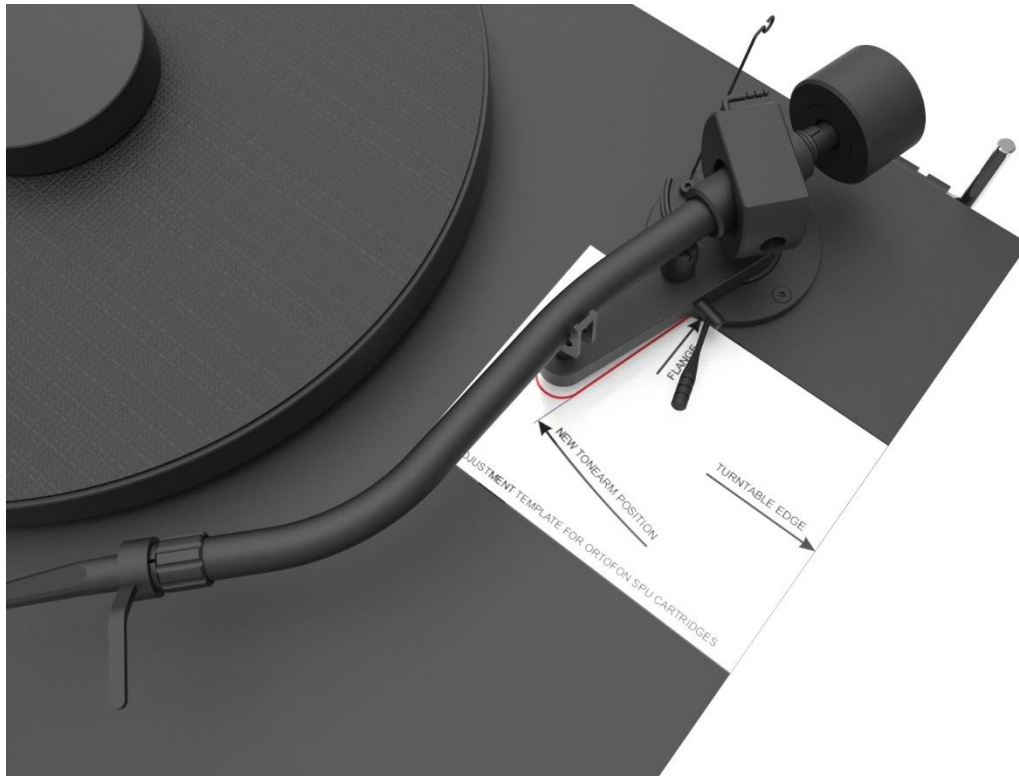

5. Maintenance and cleaning

Your record player requires little or no regular maintenance. Remove dust with a slightly moistened antistatic cloth. Never use a dry cloth because this will create static electricity which attract more dust! Antistatic cleaning fluids are available at specialist stores but must be applied sparingly to avoid damage to rubber parts. It is recommended to fit the needle cover before cleaning or maintenance is carried out to avoid damage.

If the player is not used over a long period of time the drive belt can be removed to prevent unequal stretching. The platter bearing is important for the correct speed and overall lifetime of the turntable. The oil can disappear by playing regularly or it gets dirty by rubbing of the metal (turns from grey to black). You should continually check if there is oil on the axle. In any case, it is a good idea to renew the lubrication after 3 years at the latest.



We recommend using Lube it to lubricate your platter bearing.



Always disconnect the record player from the mains power supply as a precaution before maintenance!

Technical specifications Pro-Ject Debut PRO S/ Pro-Ject 10 PRO S

Nominal speeds	33/45 r.p.m.. *** 78 r.p.m. optional
Speed variance	33: $\pm 0.40\%$ 45: $\pm 0.50\%$
Wow and flutter	33: $\pm 0.16\%$ 45: $\pm 0.14\%$
Signal to noise	68 dB
Effective tonearm mass	8g
Effective tonearm length	10 " (254mm), S-Shape aluminium, SME connector
Overhang	16 mm
Power consumption	4W/0W in Stand-By
Outboard power supply	15V / 0 – 0.8mA DC (set at 0.5mA), universal power supply
Dimensions (W x H x D)	462 x 145 x 345mm
Weight	7.0kg
Dimensions packaging (W x H x D)	488 x 235 x 393mm
Weight incl. packaging	9.0kg

Technical specifications Pro-Ject Pick it S2 C

Frequency range	20-22.000 Hz +/-2 dB
Channel separation	24dB/1kHz
Output voltage	6mV
Recommended load impedance	47kohms
Recommended load capacitance	200-600 pF
Compliance/stylus type	7 μ m/mN – elliptical
Recommended tracking force	
Tracking angle	20mN (2g)
Internal inductance	20°
	450 mH
Weight	7.2g

Potential incorrect use and fault conditions

Pro-Ject turntables are manufactured to the highest standards and undergo strict quality controls before leaving the factory. Faults that may possibly occur are not necessarily due to material or production faults but can sometimes be caused by incorrect use or unfortunate circumstances. Therefore, the following list of common fault symptoms is included.

The platter doesn't turn although the unit is switched on:

- The unit is not connected to the mains power supply.
- No mains at the socket.
- Drive belt is not fitted or has slipped off.

No signal through one or other channel or both channels:

- No signal contact from the cartridge to the internal tonearm wiring or from that to the arm lead or from that to the phono box or between that and the amplifier. This could be due to a faulty plug, broken wire or solder joint or simply loose plug/socket connection.
- Phono input not selected at amplifier.
- Amplifier not switched on.
- Amplifier or speakers defective or muted.
- No connection to the loudspeakers.

Strong hum on phono input:

- No earth connection from cartridge or arm or arm cable to amplifier, or earth loop.

Distorted or inconsistent sound from one or both channels:

- Record player is connected to wrong input of amplifier, or MM/MC switch incorrectly set.
- Needle or cantilever damaged.
- Wrong r.p.m., drive belt overstretched or dirty, platter bearing without oil, dirty or damaged.

Service

Should you encounter a problem which you are not able to alleviate or identify despite the above information, please contact your dealer for further advice. Only when the problem cannot be resolved there should the unit be sent to the responsible distributor in your country.

Guarantee repairs will only be effected if the unit is returned correctly packaged. For this reason, we recommend keeping the original packaging.

Never return a record player without making sure that it is safely disassembled and correctly packaged in the original packaging according to the diagrams on the last page of this user guide. Please remove these parts and pack them separately: lid (10), counterweight (6), anti-skating weight (15) platter (5) and belt (3). Fit the cartridge protection cap. Insert the transport lock for the tonearm (8) prior to carefully packaging the record player.

Warranty



The manufacturer accepts no responsibility for damage caused by not adhering to these instructions for use and/or by transportation without the original packaging. Modification or change to any part of the product by unauthorized persons release the manufacturer from any liability over and above the lawful rights of the customer.

PRO-JECT is a Registered Trademark of H. Lichtenegger.

This guide was produced by: Pro-Ject Audio Systems
Copyright © 2022. All rights reserved.

The information was correct at the time of going to press. The manufacturer reserves the right to make changes to the technical specification without prior notice as deemed necessary in the process of technical development.

